

Unified Quiz M4

May 7, 2008

M - PORTION

- Put the last four digits of your MIT ID # on each page of the exam.
- Read all questions carefully.
- Do all work on that question on the page(s) provided. Use back of the page(s) if necessary.
- Show all your work, especially intermediate results. Partial credit cannot be given without intermediate results.
- Show the logical path of your work. Explain clearly your reasoning and what you are doing. *In some cases, the reasoning is worth as much (or more) than the final answers.*
- Please be neat. It will be easier to identify correct or partially correct responses when the response is neat.
- Be sure to show the appropriate units throughout. Answers are not correct without the units.
- Report significant digits only.
- Box your final answers.
- **Calculators are allowed.**
- **Print-outs of Handout "HO-M-14" along with 2 sides of pages of handwritten material are allowed.**

EXAM SCORING

#1M (1/3)	
#2M (1/3)	
#3M (1/3)	
FINAL SCORE	

PROBLEM #1M (1/3)

An aircraft structure is to be designed using either the basic strength approach or the damage tolerance approach. The component is loaded such that analysis shows that the material is subjected to a planar stress state with the stress in the x-direction being twice the stress in the y-direction and three times the shear stress in the plane. All stresses are proportional to a loading parameter A. Titanium and aluminum are being considered for this piece. The particular titanium has a modulus of 16.4 Msi, a Poisson's ratio of 0.31, a value of the tensile ultimate strength of 135 ksi, and a value of fracture toughness of $60 \text{ ksi(in)}^{1/2}$. The particular aluminum has a modulus of 10.3 Msi, a Poisson's ratio of 0.30, a value of the tensile ultimate strength of 50 ksi, and a value of fracture toughness of $30 \text{ ksi(in)}^{1/2}$.

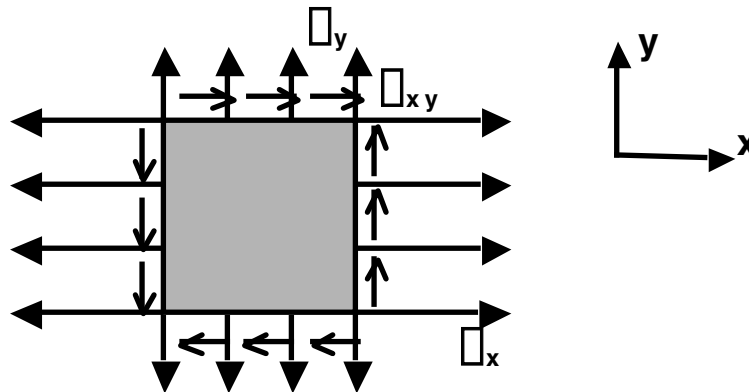

The thickness must be determined for the various considerations.

- (a) Using the Tresca criterion and the tensile ultimate strength, the necessary thickness for the titanium is 0.25 inches for the critical value of the loading parameter A. Determine the needed thickness for the aluminum for this critical value of the loading parameter and this criterion. Explain carefully using equations as needed.

PROBLEM #1M (continued)

- (b) Using the damage tolerance approach for Mode I considerations and using only the stress normal to a critical crack size of 0.50 inches, it is determined that the necessary thickness for the titanium is 0.20 inches for the critical value of the loading parameter A . Determine the needed thickness for the aluminum for this critical value of the loading parameter and this criterion. Explain carefully using equations as needed.

PROBLEM #1M (continued)

PROBLEM #2M (1/3)

A shaft configuration has been chosen to be used as a metering device to determine torque applied in an overall system. The shaft is clamped to a solid wall at one end and is free at the other. Attached to that free end of the shaft is an arrow to indicate the rotation of the shaft. The structural configuration is loaded by a distributed torque of linear decreasing magnitude varying from a key measurement value, a , at the wall to half that value at the free end. In addition, there is a concentrated torque of $(-10a)$ m at the midpoint of the shaft. The shaft is 3 meters long and has a solid square cross-section with a side length of 100 mm. The shaft is made of steel with a Young's modulus of 200 GPa, a Poisson's ratio of 0.3, and a yield stress of 350 MPa. For the critical value of the loading parameter, a , a tip rotation of 1° occurs.

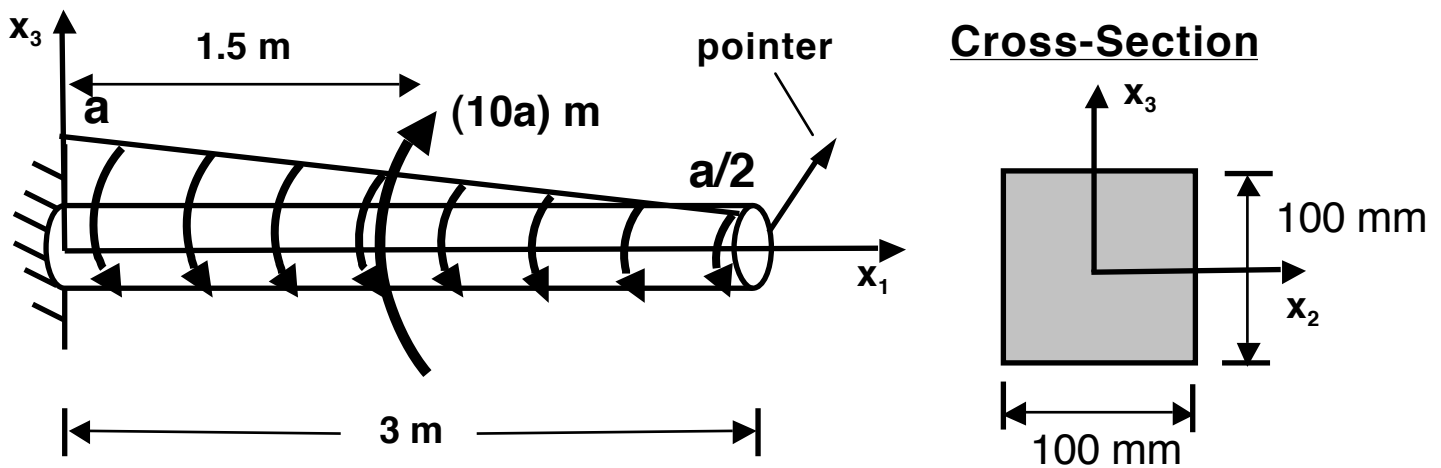

- (a) Due to corrosion issues, an aluminum shaft of the same geometrical configuration is being considered. Aluminum has a Young's modulus of 70 GPa, a Poisson's ratio of 0.3, and a yield stress of 200 MPa. Determine the tip rotation for the aluminum shaft for the same value of the critical loading.

PROBLEM #2M (continued)

PROBLEM #2M (continued)

- (b) A circular cross-section with a diameter equal to the side length of the square cross-section is being considered for the aluminum case. Will the tip rotation increase or decrease from the case of the aluminum square cross-section? Explain carefully using equations as needed.

PROBLEM #3M (1/3)

A component of a piece of heavy construction will have a circular cross-section. This piece can be modeled as a component that is connected to a roller support at one end, where the load is applied, with a torsional spring of stiffness k_T at that end allowing moment to be transferred to the surrounding walls. The component is pinned at the other end. The component is to be sized with regard to diameter, d , and length, L . The component will be made of machinery-grade steel with a modulus of 70 Msi and an ultimate stress of 60 ksi.

Cross-Section

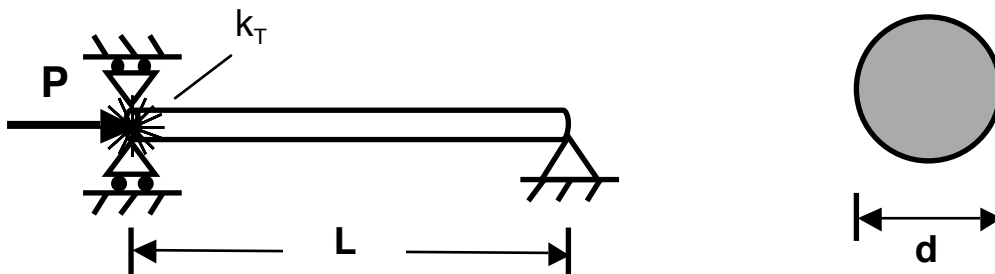

Set up the equation(s) needed to determine the maximum load of this component assuming that manufacturing, alignment, and loading are “perfect”. This includes any deformation prior to instability. Describe how you would use the resulting equation(s) to determine the response but **DO NOT SOLVE**. Use figures if/as appropriate.

PROBLEM #3M (continued)

PROBLEM #3M (continued)